



Huntersville Public Art Commission
Department of Parks and Recreation
Public Call for Artists and Request for Proposal
Mosaic Bench
(RFP-HPAC-002)

Deadline: Monday March, 11 2019
5:00PM EST

Request for Qualifications (RFP-HPAC-002)

Mosaic Bench

Overview:

The Town of Huntersville and Huntersville Public Art Commission is seeking a permanent public mosaic topped concrete bench display located immediately in front of the Huntersville Arts and Cultural Center located at 109 Old Statesville Rd. Huntersville, NC 28078. The selected design will become an interactive element of the annual Hello Huntersville festival on May 5, 2019 from 2p-6p where the public will be encouraged to participate in assisting the artist to build the mosaic as a segment of the festival. Upon completion, the bench will become a permanent display and publicly used bench. Thank you for your interest!

Deadline:

This call and request for proposals is open until 5:00PM on Monday, March 11, 2019. To ensure fairness to all, requests for any extensions or waivers of deadlines will not be granted. The HPAC reserves the right to postpone, suspend, cancel or extend this deadline at any time and through public notice.

Eligibility:

This call is open to all artists who currently live or work in the State of North Carolina. Submitted designs must be original and represent creatively interactive use of mosaic tiles. Submitted designs can be created in any medium so long as it can be submitted digitally.

Selection Process:

A selection committee which includes representatives from the HPAC and Town of Huntersville will review all submitted proposals within 30 days from the RFP deadline of March 11, 2019. Review of submitted designs will begin Tuesday, March 12, 2019 with a final decision expected on or before Friday, March 15, 2019.

The selection committee will then present the recommended design to the Huntersville Town Board of Commissioners on Monday March 18, 2019 for final approval.

Selection Criteria:

The selection committee will use the following criteria in determining the finalist:

- Innovation and creativity in prior projects and proposed design.
- Demonstrated craftsmanship and technical knowledge of working with mosaic tiles.
- Provided estimate of all costs including materials, labor, supplies, travel and any other expenses other than the concrete bench provided by the Town of Huntersville.
- Knowledge and proficiency in protecting permanent displays from weather commonly found in Huntersville, NC.
- Preference will be given to Huntersville and Charlotte-Mecklenburg County based artists.
- Artist's creativity in implementing the town logo in the design (seen right).
- Completeness of the application process as outlined in this announcement.



Hello Huntersville Activation:

Hello Huntersville is our annual celebration of music and arts! The festival is scheduled for Sunday May 5th, 2019 from 2:00pm-6:00pm and draws more than 5,000 visitors each year. As an annual citizen arts engagement showcase, the selected artist will host a demonstration area

featuring the new bench and mosaic design template. With support from the HPAC and Town the selected artist will be expected to communicate and educate the general public on what the mosaic is, how it is created and encourage participation in the placement of mosaic tiles to all interested festival participants.

Location:

The location of the bench will adorn the landscape of the Huntersville Arts & Culture Center and be integrated onto the sidewalk which will be widened to accommodate the seating area for the public bus stop.



The bus stop sign and directional sign for I-77 will remain in place. The Town of Huntersville will widen the sidewalk by an estimated (2' x 7' x 2') prior to installation. At this time there is not substantial lighting in this area in the evening, but the Arts & Cultural Building's sign is occasionally illuminated following sunset. Old Statesville Rd. is one of busiest roads in the town creating an outstanding opportunity for the selected artist to receive high yield exposure.



The area is exposed to the elements of weather which include four seasons with hot summers and annual snow and ice storms.

Budget:

The full budget for this project is \$5,000 to include all materials, supplies and subsidies with exception to the concrete bench which the Town will provide.

The Bench:



Please refer to the following information taken from the manufacturers specifications guide.
https://www.theparkcatalog.com/amfilerating/file/download/file_id/32892/

MANUFACTURING

All precast work shall be true to dimension and have clean, accurate finishes and details faithfully executed. Reinforcing steel shall conform to work and shall have a minimum compressive strength of 5,000 psi at 28 days of age when tested by means of cylinder molds (6x12) from the materials. There shall be a maximum of 4-6% air entrainment for all precast according to ASTM standards.

REINFORCEMENT

All concrete products have reinforcement characteristics such as rebar or fiberglass.

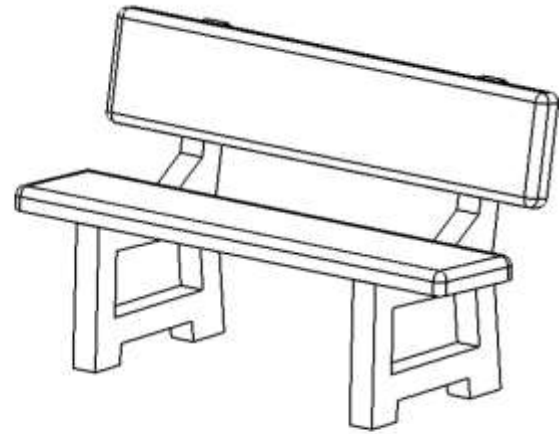
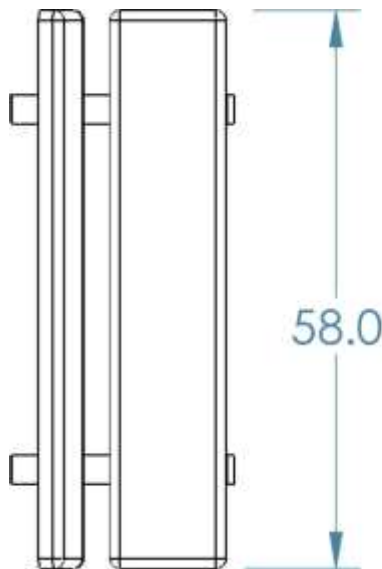

MOLDS

The forms for the precast units shall be constructed of metal or fiberglass laminated designed to withstand casting pressures without distortion. All anchors, inserts, bolts, etc. will be placed and secured in the forms as required for the attachment and handling of the units. These shall be clamped so as to hold them in position.

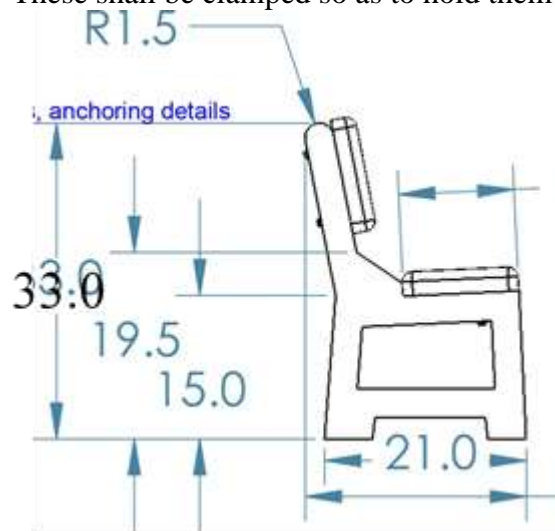

PHYSICAL CHARACTERISTICS

All exposed surfaces are treated to remove the surface matrix and exposed the aggregate produced by chemical retardant - not sand blasting. All precast shall have the water repellent sealer treatment applied in strict accordance with manufacturer's specifications. All tolerances shall be within 1/8" of specified dimensions, designed for structural analysis and calculation.

MATERIALS

Portland cement: ASTM C150 Type 1 or 3
All aggregate to meet ASTM C33 Specifications

Timeline:

February 25, 2019	Call to Artist Announcement/RFP
March 11, 2019	Response from Artist Due by 5:00PM EST
March 12, 2019	HPAC Review Process Begins & Finalized
March 18, 2019	HPAC Presents Recommendation to Town Board
March 19, 2019	Selected Artist Contacted
May 5, 2019	Hello Huntersville: Mosaic Activation

How To Apply:

All qualified and interested artists are encouraged to apply. All application requirements must be met to be considered. All applications, submissions and questions should be directed to Alison Ahrens at AAhrens@huntersville.org / 704-766-2253 / 105 Gilead Rd. Floor 3, Huntersville, NC 28078.

All submissions are due by 5:00PM Monday, March 11, 2019.

1. One page statement of interest briefly describing the concept design and your inspiration behind the design.
2. One page resume or curriculum vitae.
3. Design Proposals: You may submit up to a maximum of 3 different designs for consideration. All designs should be submitted separately with its own statement of interest as explained in item 1.
4. All images should be medium to high resolution (50dpi, 800x600px minimum) JPEG files, a maximum of 4 draft images per submission.
5. Samples of your other work. Up to 10 images with descriptions to include title, date, size, medium and for public art location, commissioning organization, item description and budget.